



## Warranty

All materials and workmanship used in the construction of its incinerator and the refractory are guaranteed for a one year period from the date of installation. All purchased electrical parts such as burners, fans, timers, and other controls will carry the applicable manufacturer's guarantee of 90 days. Seller shall not be liable for any injury or damages to person or property or any other incidental or consequential damages.

### Specifications

- **Height:** 8'4" (11'1" w/ Secondary Chamber) **Length:** 7' **Width:** 4'
- **Weight:** 5,000 lbs (6,000 lbs with secondary chamber)
- **Metal:** 11 gauge
- **Lining:** 3" walls, 4" ends 3000° refractory
- **Swine Charge Door:** 4'4" x 20" Lining: 4" 3,000° refractory
- **Stack:** 4'4" Lining: 2-inch refractory lining
- **Ash Door:** 6" x 11" (both ends)  
Lining: 2-inch 3000° refractory
- **Grates:** No grates
- **Burners:** 2 300,000 BTU incriminate with cover  
50,000 BTU Second Chamber burner with cover.
- **Clean-out Rod:**
- **Two Timers:** 6 hour

### Guarantee

Every unit is constructed of the highest quality materials and built by skilled technicians. Each incinerator bears the label assurance of long life and trouble-free operation.

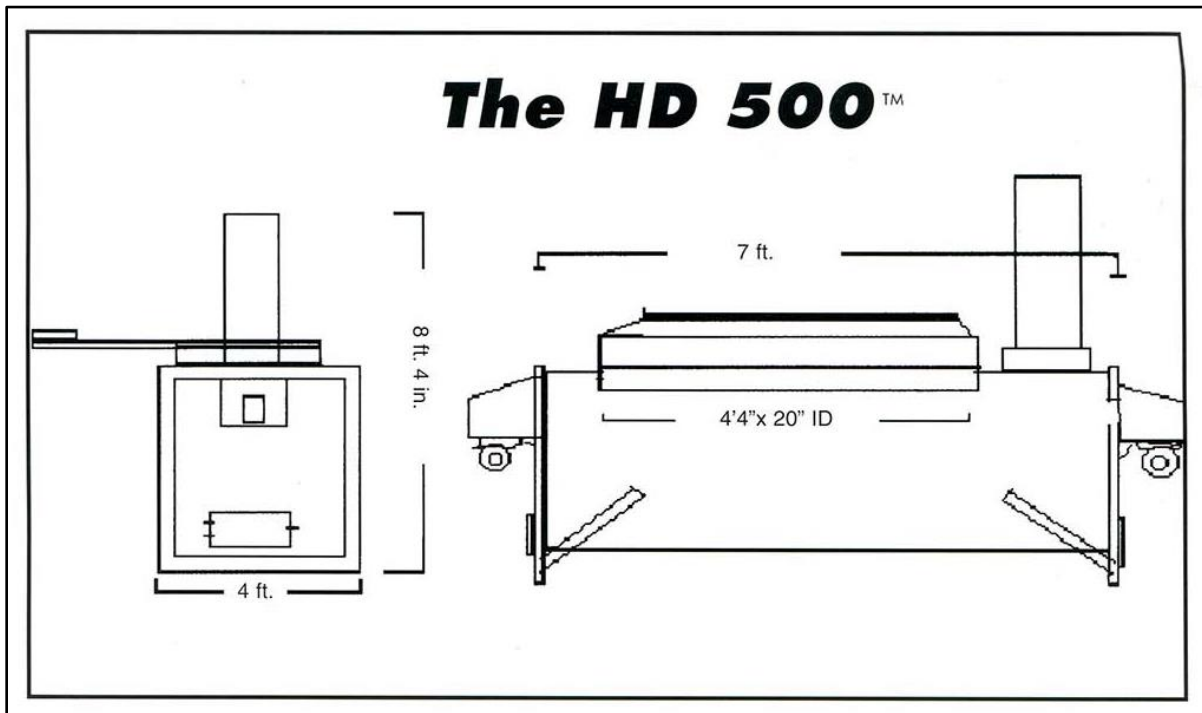

647-0340634  
 340-3750-308-3



647-0340634-4  
 583  
 NBSN8CTPSN